

COMPUTATIONAL MODELLING OF STEADY CRACK EXTENSION IN POROELASTIC MEDIA

A. P. S. SELVADURAI† and A. T. MAHYARI

Department of Civil Engineering and Applied Mechanics, McGill University,
817 Sherbrooke Street West, Montreal, QC, Canada H3A 2K6

(Received 25 April 1997; in revised form 11 February 1998)

Abstract—The steady state constant velocity crack extension in poroelastic media is examined for plane strain problems. The finite element formulation of the governing equations for steady crack extension in poroelastic media is developed using a Galerkin technique. The resulting system of non-symmetric coupled matrix equations depends on the propagation velocity at the crack tip. The computational scheme accounts for the stress singularity in the effective stress field at the crack tip. The numerical procedure is verified by comparison with analytical solutions for the pore pressure and displacement fields at the crack tip. The computational procedure is utilized to examine the plane strain problem related to the steady growth of a crack in a poroelastic medium due to its wedging by a rigid smooth indenter. It is shown that the computational methodology can also be applied to examine the penetration of an axisymmetric rigid smooth shell through a saturated geomaterial. © 1998 Elsevier Science Ltd. All rights reserved.

1. INTRODUCTION

The theory of poroelasticity developed by Biot (1941, 1955) accounts for the coupled processes of fluid flow and elastic deformation of a porous medium which is saturated with either an incompressible or a compressible pore fluid. Recent reviews (see e.g. Selvadurai, 1996) indicate that the theory of poroelasticity has been successfully applied in the study of variety of problems in geomechanics, biomechanics, materials engineering, environmental geomechanics and energy resource recovery from geological formations. As the applications of the theory diversify, attention needs to be focused on other aspects of importance. With porous brittle geomaterials which are saturated with fluids, the study of the initiation and extension of cracks is recognized as an area of both practical and fundamental interest. This paper focuses on the finite element modelling of the steady crack extension phenomena in poroelastic media.

The problem of steady state constant velocity crack growth in an isotropic elastic medium was first examined by Yoffe (1951) for the case of plane strain deformation. Radok (1956) and Broberg (1960) extended this study to examine the steady self-similar extension of a crack in an elastic material. The limits of propagation velocity in these studies are established in relation to Rayleigh wave velocity in elastic materials. A recent review of these developments is presented by Freund (1990). In the context of poroelasticity, Rice and Simons (1976), Simons (1977) and Ruina (1978) have given analytical solutions to problems of a semi-infinite crack propagating quasi-statically in shear mode through a saturated porous medium, for various pore pressure boundary conditions on the crack faces. Cheng and Liggett (1984) applied the boundary integral equation method to solve a similar problem. The quasi-static crack growth governs the hydraulic fracturing phenomena used quite extensively in oil resource recovery (Ingraffea and Boone, 1988). Fracture extension in poroelastic media is of considerable interest to hydraulic fracture of resource bearing geological formations. A review of contributions in this area is given by Boone *et al.* (1991). The problem of a stationary hydraulic fracture in a poroelastic medium is given by Detournay and Cheng (1991). The behaviour of a crack tip region during hydraulic fracturing by a fluid which has a power law constitutive response is given by Desroches *et*

† Author to whom correspondence should be addressed. Tel.: 001 514 398 6672. Fax: 00 514 398 7361.
E-mail: apss@civil.lan.mcgill.ca

al. (1994). Recently Craster and Atkinson (1991, 1996) have examined in more detail the crack tip stress and pore pressure fields for steadily propagating semi-infinite cracks in poroelastic media. They have given the analytical solutions for the pore pressure and stress fields near the crack of tip for various boundary conditions applied to pore pressure and tractions on the crack faces.

In poroelastic and other materials which exhibit dissipative phenomena the extension of a crack is likely to be dynamic and unsteady in the initial stages. However, a steady state of crack extension can be obtained at limiting times when the crack extension has occurred over a long period of time. For poroelastic materials the flow of energy into the pore fluid tends to stabilize the crack growth and results in a quasi-static extension of the crack with a certain velocity. To preserve the conditions of steady state of crack extension, the traction distribution should be time invariant in a reference coordinate system moving with the crack tip in an infinite poroelastic medium. The study of phenomena related to quasi-static crack propagation in poroelastic geomaterials can be of interest to development of landslides in overconsolidated clay (Palmer and Rice, 1973; and Rice and Cleary, 1976) and aftershock events in an earthquake (Booker, 1974).

The plane strain problem of the steady quasi-static propagation of a crack, in a poroelastic medium, moving at a finite velocity and driven by tensile tractions (Fig. 1) is examined in this study. While this class of two-dimensional plane strain problems give rise to steady state crack extension phenomena, the equivalent class of problems involving extension of circular cracks do not yield a steady state. The steady state crack extension behaviour of saturated materials is assumed to depend on the velocity of crack propagation. The response of material is assumed to be fully drained at low propagation velocities and undrained at high velocity limits. As a result, the stress field near the crack tip will be a function of propagation velocity. When the assumptions of steady state crack extension are invoked the governing equations of poroelasticity are modified. The modification takes the form of the elimination of the time variable by a suitable transformation which accounts for the propagation velocity at the crack tip. We present the basic equations governing the steady state extension of a semi-infinite crack under conditions of plane strain and that of a cylindrical crack exhibiting a state of axial symmetry. The finite element formulation of the transformed equations governing the steady state extension of a crack in a poroelastic medium is developed by employing a Galerkin technique. The finite element approximation results in a system of non-symmetric coupled matrix equations which are velocity-dependent. The numerical procedure accounts for the singular behaviour of the effective stress state at the crack tip located in the poroelastic medium. The computational scheme is verified by appeal to analytical solutions given by Rice and Simons (1976) and Craster and Atkinson (1991) for the pore pressure and displacement fields at the crack tip. The numerical procedure is first utilized to examine the plane strain problem related to the steady growth of a crack due to its wedging either by a rigid cylindrical indenter (dipole of point forces) or by a smooth rigid strip indenter. The computational methodology is then applied to

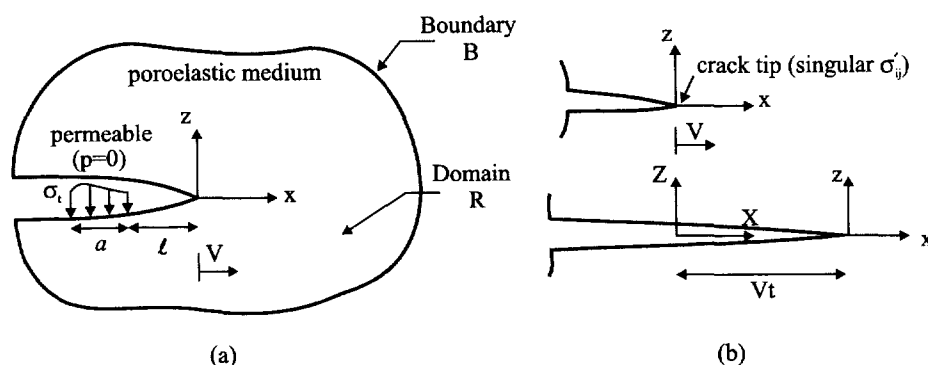

Fig. 1. Steady extension of a crack in a poroelastic medium.

examine the penetration of an axisymmetric rigid smooth cylindrical shell with a “blunt front” through a saturated brittle geomaterial.

2. GOVERNING EQUATIONS

The basic equations governing Biot’s theory of poroelasticity are summarized for completeness. The constitutive equations governing the quasi-static response of a poroelastic medium, which consists of a porous isotropic elastic soil skeleton saturated with a compressible pore fluid take the forms

$$\sigma_{ij} = 2\mu\varepsilon_{ij} + \frac{2\mu\nu}{1-2\nu}\varepsilon_{kk}\delta_{ij} + \alpha p\delta_{ij} \quad (1a)$$

$$p = \beta\zeta_v + \alpha\beta\varepsilon_{kk} \quad (1b)$$

where σ_{ij} is the total stress tensor; p is the pore fluid pressure; ζ_v is the volumetric strain in the compressible pore fluid; ν and μ are, respectively, the “drained values” of the Poisson’s ratio and the linear elastic shear modulus, applicable to the porous fabric, δ_{ij} is Kronecker’s delta function. In (1), ε_{ij} is the soil skeleton strain tensor which is defined by

$$\varepsilon_{ij} = \frac{1}{2}(u_{i,j} + u_{j,i}) \quad (2)$$

where u_i are the displacement components, and a comma denotes a partial derivative with respect to the spatial variables. The material properties α and β which define, respectively, the compressibility of the pore fluid and the compressibility of the soil fabric are given by

$$\alpha = \frac{3(v_u - \nu)}{\tilde{B}(1-2\nu)(1+v_u)} \quad (3a)$$

$$\beta = \frac{2\mu\tilde{B}^2(1-2\nu)(1+v_u)^2}{9(v_u - \nu)(1-2\nu)} \quad (3b)$$

where v_u is the undrained Poisson’s ratio, and \tilde{B} is pore pressure parameter introduced by Skempton (1954). The effective stress tensor σ'_{ij} of the porous skeleton is given by

$$\sigma'_{ij} = \sigma_{ij} - \alpha p\delta_{ij} \quad (4)$$

In the absence of body forces and dynamic effects, the quasi-static equations of equilibrium for the complete fluid saturated porous medium take the form

$$\sigma_{ij,j} = 0 \quad (5)$$

The fluid transport within the pores of the medium is governed by Darcy’s law which can be written as

$$v_i = -\kappa p_{,i} \quad (6)$$

where v_i are the components of the specific discharge vector in the pore fluid and $\kappa = k/\gamma_w$, in which k is the coefficient of hydraulic conductivity of porous material and γ_w is the unit weight of pore fluid. The equation of continuity associated with quasi-static fluid flow is

$$\frac{\partial\zeta_v}{\partial t} + v_{i,i} = 0 \quad (7)$$

Considering requirements for a positive definite strain energy potential (see e.g. Rice and

Cleary, 1976), it can be shown that the material parameters should satisfy the following thermodynamic constraints: $\mu > 0$; $0 \leq \tilde{B} \leq 1$; $-1 < \nu < \nu_u \leq 0.5$; $\kappa > 0$.

The resulting equations of equilibrium for a poroelastic medium as introduced by Biot (1941, 1955) and reformulated in more physically relevant variables by Rice and Cleary (1976), can be written in terms of the displacements and pore pressure as

$$\mu \nabla^2 u_i + \frac{\mu}{(1-2\nu)} \varepsilon_{kk,i} + \alpha p_{,i} = 0 \quad (8a)$$

$$\kappa \beta \nabla^2 p - \frac{\partial p}{\partial t} + \alpha \beta \frac{\partial \varepsilon_{kk}}{\partial t} = 0 \quad (8b)$$

To formulate the governing equations for steady crack extension in poroelastic media, we consider the idealized problem of a semi-infinite plane crack moving steadily in a poroelastic medium. It is assumed that the coordinate system is located at the tip of the moving crack (Fig. 1). The crack moves along the x -direction with a constant velocity V . The problem is assumed to be quasi-static and inertial effects and body forces in the medium are neglected. The acceleration of the system is also assumed to be zero. We consider the transformation

$$x = X - Vt; \quad z = Z \quad (9)$$

where x - z is a coordinate reference system moving with the crack tip. The explicit time-dependency can be removed by writing

$$\frac{\partial}{\partial t} = -V \frac{\partial}{\partial x} \quad (10)$$

The resulting time-independent equations of poroelasticity take the form

$$\mu \nabla^2 u_i + \frac{\mu}{(1-2\nu)} \varepsilon_{kk,i} + \alpha p_{,i} = 0 \quad (11a)$$

$$\kappa \beta \nabla^2 p + V \frac{\partial p}{\partial x} - \alpha \beta V \frac{\partial \varepsilon_{kk}}{\partial x} = 0 \quad (11b)$$

Since time dependency is eliminated through transformation (9), for a well posed boundary value problem, only boundary conditions need to be specified on the variables u_i , σ_{ij} and p .

3. FINITE ELEMENT FORMULATIONS

Finite element methods have been widely applied for the study of problems in poroelasticity (see e.g. Sandhu and Wilson, 1969; Ghaboussi and Wilson, 1973; Booker and Small, 1976). Reviews of both analytical and computational procedures for the study of soil consolidation related to poroelastic media are given by Lewis and Schrefler (1987) and Selvadurai (1996). Applications of Galerkin procedures in finite element modelling to the study of poroelastic media are well documented by Sandhu and Wilson (1969), Lewis and Schrefler (1987), and more recently, by Selvadurai and Nguyen (1995) in connection with isothermal consolidation of sparsely jointed porous media. The Galerkin approximation technique is applied to the governing eqns (11) to transform the partial differential equations into a discretized matrix form. The approximation used for the displacements u_i and pore pressure p can be obtained by

$$\begin{aligned} \underline{u} &= N^u \{ \mathbf{u} \} \\ \underline{p} &= N^p \{ \mathbf{p} \} \end{aligned} \quad (12)$$

where $\{\mathbf{u}\}$ and $\{\mathbf{p}\}$ are the nodal displacements and pore pressures, and N^u and N^p correspond to the nodal shape functions for displacement and pore pressure fields. In general N^u and N^p can be different but both N^u and N^p must exhibit C^0 continuity. First, the Galerkin procedure is applied to the eqn (11b) which results in the following weak (weighted residual) form of the equation

$$\int_R N^p \left[\kappa \frac{\partial^2 p}{\partial x_i^2} + \frac{V}{\beta} \frac{\partial p}{\partial x_r} - \alpha V \frac{\partial}{\partial x_r} \left(\frac{\partial u_k}{\partial x_k} \right) \right] dR = 0 \quad (13)$$

where R is the domain of interest, and we note that $x_1 = x$; $x_2 = z$; and $x_r = x$. Application of Green's theorem to above equation results in the following

$$\int_B N^p \kappa \left(\frac{\partial p}{\partial x_i} n_i \right) dB - \int_R \frac{\partial N^p}{\partial x_i} \kappa \frac{\partial p}{\partial x_i} dR + \int_R \frac{V}{\beta} N^p \frac{\partial p}{\partial x_r} dR - \int_B \alpha V N^p \frac{\partial u_k}{\partial x_k} n_x dB + \int_R \alpha V \frac{\partial N^p}{\partial x_r} \frac{\partial u_k}{\partial x_k} dR = 0 \quad (14)$$

where B is the boundary of domain R . By substituting the interpolation functions given by eqns (12) in the above equation, one obtains

$$\int_R \frac{\partial N^p}{\partial x_i} \kappa \frac{\partial N^p}{\partial x_i} p_k dR - \int_R \frac{V}{\beta} N^p \frac{\partial N^p}{\partial x_r} p_k dR + \int_B \alpha V N^p \frac{\partial N^u}{\partial x_i} n_x u_{ij} dB - \int_R \alpha V \frac{\partial N^p}{\partial x_r} \frac{\partial N^u}{\partial x_i} u_{ij} dR = \int_B N^p \kappa \frac{\partial p}{\partial x_i} n_i dB \quad (15)$$

The above equation can be written in matrix form as

$$([\mathbf{CB}] - [\mathbf{CC}])\{\mathbf{u}\} + ([\mathbf{H}] - [\mathbf{EE}])\{\mathbf{p}\} = \{\mathbf{F}_q\} \quad (16)$$

where

$$[\mathbf{CB}] = \alpha V \int_B N^p \frac{\partial N^u}{\partial x_i} n_x dB \quad (17a)$$

$$[\mathbf{CC}] = \alpha V \int_R \frac{\partial N^u}{\partial x_i} \frac{\partial N^p}{\partial x_r} dR \quad (17b)$$

$$[\mathbf{H}] = \kappa \int_R \frac{\partial N^p}{\partial x_i} \frac{\partial N^p}{\partial x_i} dR \quad (17c)$$

$$[\mathbf{EE}] = \frac{V}{\beta} \int_R N^p \frac{\partial N^p}{\partial x_r} dR \quad (17d)$$

and $\{\mathbf{u}\}$ is the displacement vector; $\{\mathbf{p}\}$ is the pore pressure vector $\{\mathbf{F}_q\}$ is the outward fluid flux through the boundary B . The finite element approximation for the equilibrium equation can be derived by a similar approach (see e.g. Sandhu and Wilson, 1969; Selvadurai and Nguyen, 1995) which takes the form

$$[\mathbf{K}]\{\mathbf{u}\} + [\mathbf{C}]\{\mathbf{p}\} = \{\mathbf{F}_b\} \quad (18)$$

where

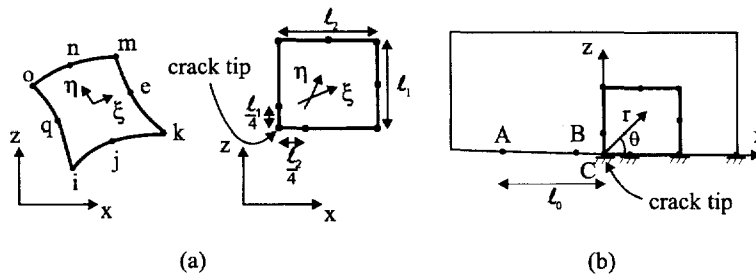

Fig. 2. (a) Plane and quarter point isoparametric elements; and (b) node arrangement for computation of the stress intensity factor.

$$[\mathbf{C}] = \alpha \int_R \frac{\partial N^u}{\partial x_i} N^p dR \quad (19a)$$

$$[\mathbf{K}] = \int_R [\mathbf{B}]^T [\mathbf{D}] [\mathbf{B}] dR \quad (19b)$$

where $[\mathbf{D}]$ is the stress-strain matrix for the soil skeleton which depends on two elastic constants μ and ν and $[\mathbf{B}]$ is the matrix relating strains to nodal displacements which depends on the shape functions N^u .

The finite element formulation of the steadily propagating crack in a poroelastic medium can be written by combining the eqns (16) and (18). The non-symmetric matrix form of the discretized equations takes the form

$$\begin{bmatrix} [\mathbf{K}] & [\mathbf{C}] \\ [\mathbf{CB} - \mathbf{CC}] & [\mathbf{H} - \mathbf{EE}] \end{bmatrix} \begin{Bmatrix} \mathbf{u} \\ \mathbf{p} \end{Bmatrix} = \{\mathbf{F}\} \quad (20)$$

where

- \mathbf{K} = stiffness matrix of the soil skeleton;
- \mathbf{C} = coupling matrix related to interaction between soil and pore fluid;
- \mathbf{CC} = modified coupling matrix;
- \mathbf{CB} = coupling matrix associated with the boundary conditions;
- \mathbf{EE} = modified compressibility matrix of fluid;
- \mathbf{H} = permeability matrix;
- \mathbf{F} = force vectors due to external tractions, body forces and flow field;
- \mathbf{u} = vector of nodal displacements;
- \mathbf{p} = vector of pore pressures

The governing eqns (20) are discretized in the spatial domain using a standard finite element procedure. The element chosen to represent the intact region of the poroelastic medium is the eight-noded isoparametric element where the displacements within the element are interpolated as functions of the eight nodes, whereas the pore pressures are interpolated as a function of only the four corner nodes i , k , m , and o (Fig. 2). The rationale for this procedure is now well documented (see e.g. Lewis and Schrefler, 1987; and Selvadurai and Nguyen, 1995).

4. COMPUTATIONAL PROCEDURES

Simons (1977) has shown that the order $r^{-1/2}$ of the stress singularity is preserved for the effective stress field at the crack tip in poroelastic media. Craster and Atkinson (1991) have shown that the pore pressure behaviour at the crack tip as $r \rightarrow 0$ is not spatially singular for steadily propagating poroelastic fracture problems. They have shown that the

pore pressure gradients at the crack tip are, however, singular for the crack problems with permeable pore pressure boundary conditions on the crack faces.

In addition to the regular isoparametric element, it is also necessary to introduce a singular element to model crack tip behaviour. The quarter point singular element introduced independently by Henshell and Shaw (1975) and Barsoum (1976), has been adopted to model the singular behaviour at the crack tip (Fig. 2). This element has been successfully utilized to model both two dimensional (plane stress and plane strain) and axisymmetric crack problems in classical elasticity. The order of the singularity in the effective stresses at the crack tip, for the porous skeleton, modelled by this approach corresponds to $r^{-1/2}$. The pore pressure field around crack tip is, however, non singular and is modelled by conventional isoparametric elements.

It is postulated that the crack in the poroelastic medium will extend when the mode I stress intensity factor applicable to the singular effective stresses at the crack tip attains a critical value of K_{Ic} . The result of particular interest is the evaluation of the critical stress intensity factor at the crack tip in relation to the propagation velocity. For plane strain problems, the crack opening or mode I stress intensity factors K_I can be evaluated by the displacement correlation method incorporating the nodes A , B , and the crack tip C (Fig. 2b) i.e.,

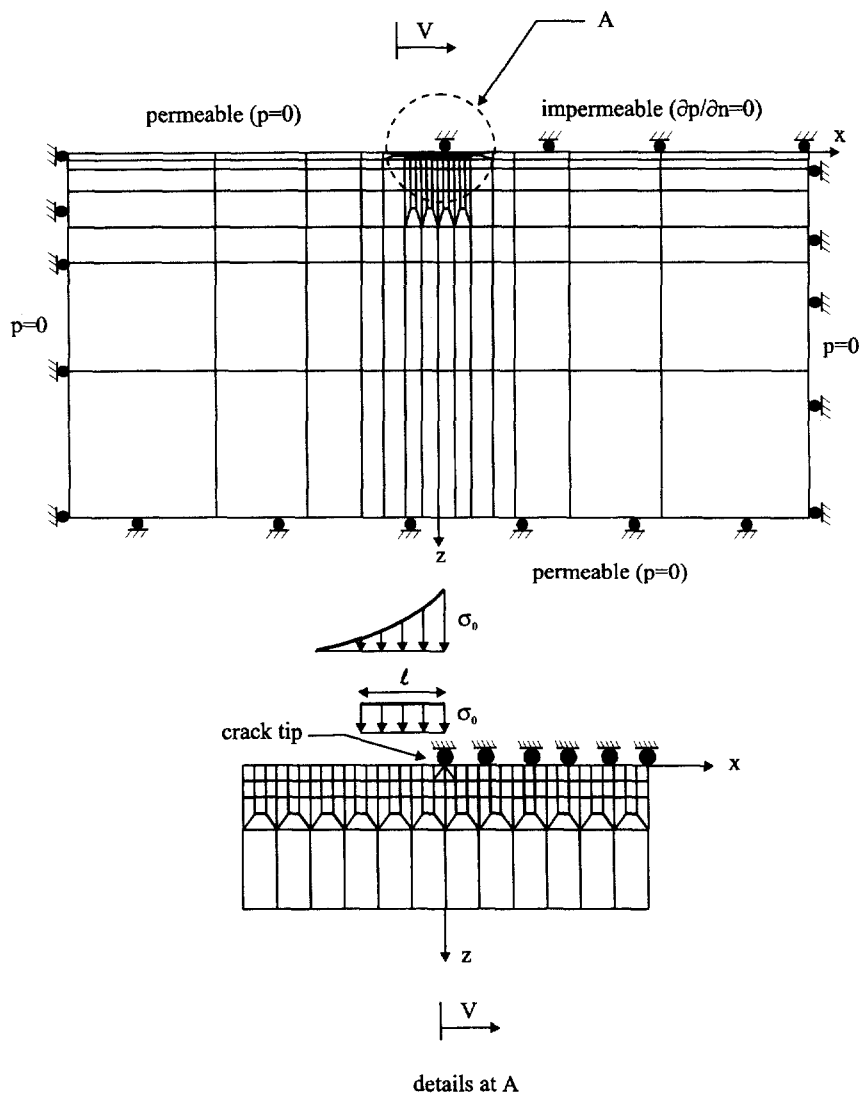

Fig. 3. Finite element discretization.

$$K_I = \frac{2\mu}{(1+k_\alpha)} \sqrt{\frac{2\pi}{l_0}} \{4u_z(B) - u_z(A)\} \quad (21)$$

where $k_\alpha = (3 - 4\nu)$ and l_0 is the length of the crack-tip element.

An examination of the literature on elastodynamic fracture mechanics indicate that the first mathematical treatment of steady crack propagation under plane strain conditions was conducted by Yoffe (1951). The scope of mathematical modelling of elastodynamic fracture phenomena was then extended by Broberg (1960) to examine solution to the steady problem of the self-similar expansion of a crack in a uniform tension stress field. Based on the positive definiteness of the energy flow to the crack tip, Broberg (1964, 1989) proved that cracks cannot propagate in crack opening mode I with velocities greater than the Rayleigh velocity c_R given by

$$c_R = \alpha_0 c_T \quad (22)$$

where c_T is the velocity of transverse (or shear) waves propagating through an elastic material which is given by

$$c_T = \sqrt{\frac{\mu}{\rho}} \quad (23)$$

where ρ is the mass density and μ is the shear modulus of elastic material, and α_0 is a constant which depends on the value of Poisson's ratio. This constant is constrained to range in a narrow domain close to unity (e.g. $\alpha_0 = 0.88$ for $\nu = 0$; and $\alpha_0 = 0.96$ for $\nu = 0.5$) and can be assumed equal to unity for most engineering applications (Davis and Selvadurai, 1996). Most of analytical solutions for the steady crack growth in poroelastic media appear to have neglected these limiting bounds on the propagation velocity which are attributed to physical phenomena. It is observed that the ratio of this critical velocity to the permeability coefficient of porous material is a key parameter which characterises the relevant limits for the steady behaviour of crack extension in poroelastic media. The relevance of these limiting bounds on poroelastic effects of crack propagation should be considered.

The computational scheme developed for the steady crack extension in poroelastic media is calibrated by comparison with the known analytical and numerical solutions. The plane strain problem of a semi-infinite crack propagating steadily in a poroelastic medium is considered. Two different traction boundary conditions on the crack faces are considered. The faces of crack are first subjected to a uniform normal total stress over a finite distance l from the crack tip. The finite element discretization of the problem and associated boundary conditions are shown in Fig. 3. The crack tip and associated loading move with a steady velocity V along the x -direction. Rice and Simons (1976) and Cheng and Liggett (1984) have given analytical and numerical solutions for the variation of the energy release rate G given by following with the velocity V :

$$G = (1 - \nu) K_I^2 / 2\mu \quad (24)$$

(It may be noted that the velocity dependence of G on V will materialize through the calculation of K_I .) The value of G varies between two limiting elastic cases of a drained value (G_e) and an undrained value. The crack extension criterion is satisfied when the energy release rate reaches a critical value G_{cr} which is dependent on the velocity V . Figure

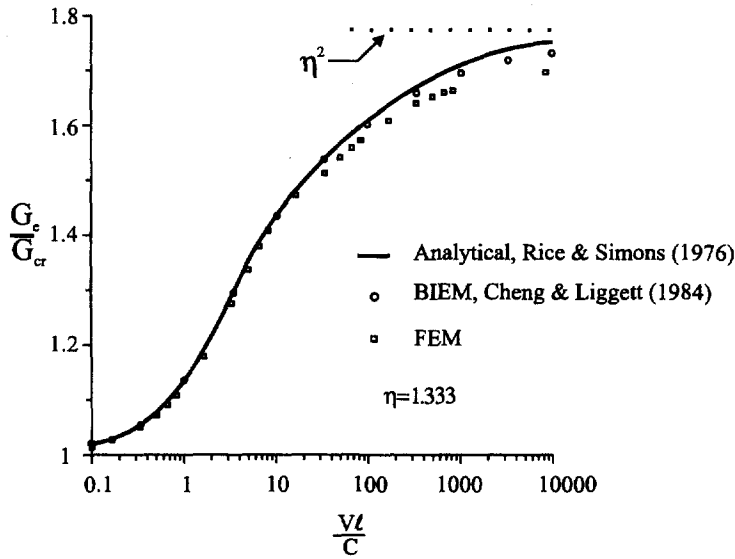

Fig. 4. Crack propagation criterion.

4 illustrates variation of the normalized critical energy release rate G_{cr} with the propagation velocity V . This parameter approaches unity as $V \rightarrow 0$ and asymptotically reaches a value η^2 (i.e. $\eta = (1 - \nu_u)/(1 - \nu)$) as $V \rightarrow \infty$. The results are compared for the case of $\eta = 1.333$ which corresponds to an overconsolidated clay (Cheng and Liggett, 1984). The maximum discrepancy of 5% occurs for very high velocity where the poroelastic effects become highly localized and pore pressure field shows spatial oscillations. Either a very fine discretization or a special crack tip element which captures the pore pressure field applicable to the high velocities, in an analytic manner, are needed to address this effect.

In the second problem examined, the faces of semi-infinite crack are subjected to an exponentially decaying normal total stress given by

$$\sigma_{zz} = \sigma_0 e^{x/a} H(t); \quad -\infty < x \leq 0 \quad (25)$$

where $H(t)$ is the Heaviside step function, and a is a constant (Fig. 3). Atkinson and Craster (1991) have given a closed form solutions for the problem for the variation of flaw opening stress intensity factor K_I with the velocity V as follows

$$K_I = f(a_1) K^e \quad (26)$$

where K^e is the elastic stress intensity factor given by $(2a)^{1/2} \sigma_0$; $f(a_1)$ is a function of normalized velocity $a_1 = aV/C$ given by the following:

(i) for a permeable crack

$$f(a_1) = \frac{1 - \nu_u}{1 - \nu + 2(\nu_u - \nu) \left(\frac{1}{a_1} - \left(\frac{1}{a_1} \left(1 + \frac{1}{a_1} \right) \right)^{0.5} \right)} \quad (27a)$$

(ii) for an impermeable crack

$$f(a_1) = \frac{1 - \nu_u}{1 - \nu + \frac{2(\nu_u - \nu)}{a_1} \left(\left(\frac{1}{a_1} \left(1 + \frac{1}{a_1} \right) \right)^{-2} - 1 \right)} \tag{27b}$$

Also the generalized consolidation coefficient C is given by

$$C = \frac{2\kappa \bar{B}^2 \mu (1 - \nu)(1 + \nu_u)^2}{9(1 - \nu_u)(\nu_u - \nu)} \tag{28}$$

Figure 5(a) illustrates the results for the variation of the stress intensity factor K_I with the normalized velocity aV/C at the crack tip, derived from analytical solutions and numerical simulations for material parameters $\nu = 0.3$, $\nu_u = 0.4$. The results indicate that there is good agreement between the analytical results and computational results. An oscillatory behaviour is also observed in the pore pressure field at the crack tip at very high velocities for this case. The nominal results also support Craster and Atkinson’s observation that the

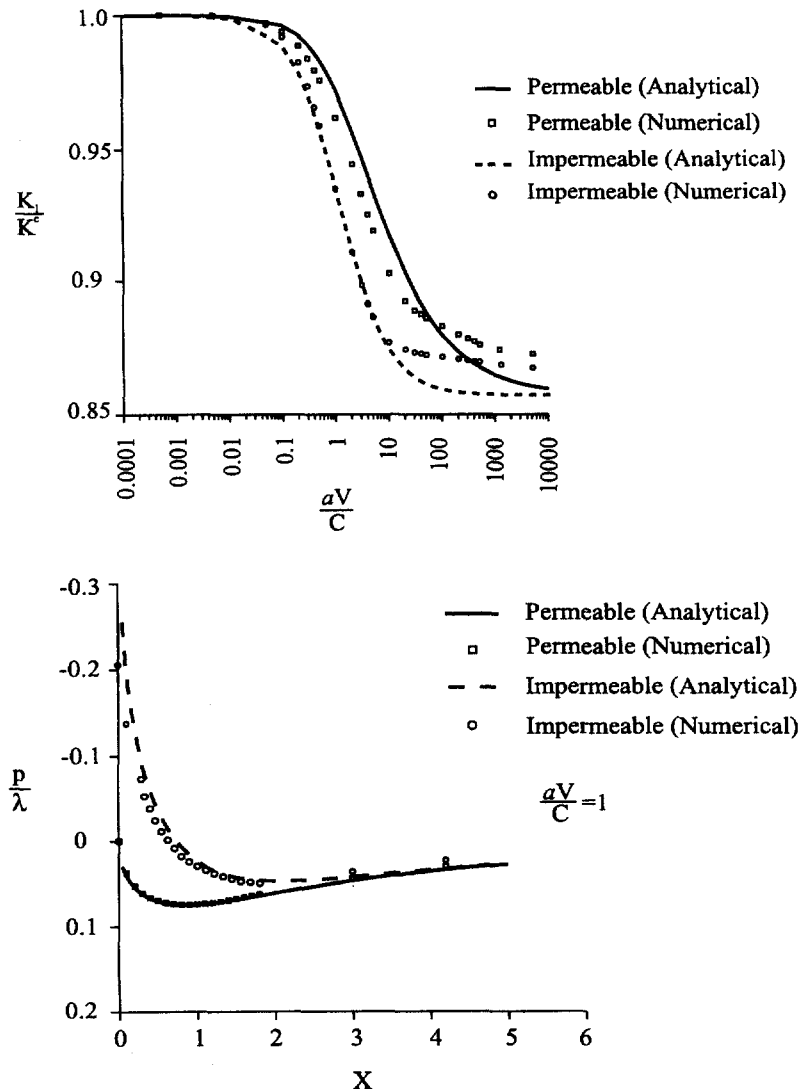

Fig. 5. (a) Variation of the stress intensity factor K_I with $a_1 = aV/C$; and (b) pore pressure distribution ahead of crack tip for velocity $a_1 = 1$. (Analytical results are due to Craster and Atkinson, 1991.)

impermeable pore pressure boundary conditions on crack faces result in a lower stress intensity factor than those applicable for the permeable case. This indirectly implies that a greater effort is required to extend cracks with impermeable surfaces of fracture.

The analytical solutions for the pore pressure fields near the crack tip are also given in an explicit form by Atkinson and Craster (1991). The pore pressure fields along the crack extension axis (x) ahead of the crack tip take the following forms:

(i) for a permeable crack

$$p(X) = \lambda \left[\left(\frac{a_1}{\pi X} \right)^{0.5} (e^{-X} - 1) - e^{X/a_1} \left(\operatorname{erfc}((X + X/a_1)^{0.5}) - \operatorname{erfc} \left(\left(\frac{X}{a_1} \right)^{0.5} \right) \right) \right] \quad (29a)$$

(ii) for an impermeable crack

$$p(X) = \lambda \left[\left(\frac{a_1}{\pi X} \right)^{0.5} (e^{-X} - 1) + e^{X/a_1} \left(\operatorname{erfc} \left(\left(\frac{X}{a_1} \right)^{0.5} \right) - \frac{\operatorname{erfc}((X + X/a_1)^{0.5})}{(1 + a_1)^{0.5}} \right) \right] \quad (29b)$$

where

$$X = (V/C)x; \quad (30a)$$

$$\lambda = \frac{2B(1 + \nu_u)(1 - \nu)\sigma_0 f(a_1)}{3(1 - \nu_u)}; \quad (30b)$$

and $\operatorname{erfc}(x)$ is the complementary error function given by

$$\operatorname{erfc}(x) = 1 - \operatorname{erf}(x) = 1 - \frac{2}{\sqrt{\pi}} \int_0^x e^{-\xi^2} d\xi \quad (30c)$$

Figure 5(b) illustrates the pore pressure distribution ahead of the crack tip for similar problem with parameters $\nu = 0.2$, $\nu_u = 0.3$ corresponding to a normalized velocity of $a_1 = 1$ for the permeable and impermeable pore pressure boundary conditions on crack faces. There is good agreement between analytical solutions and numerical results. The results indicate that a significant pore fluid suction field can be developed ahead of crack tip which reduces the effective stresses in the crack tip region particularly for permeable cracks.

5. NUMERICAL RESULTS

The class of steady state self-similar expansion of cracks in poroelastic media is of particular interest to geotechnical engineering and energy resource recovery from geological formations. The numerical procedure is utilized to examine the problem of crack growth due to symmetric wedging of a crack by rigid indentors in saturated geomaterials under conditions of plane strain and axial symmetry.

The mathematical treatment of steady-state self-similar crack extension under plane strain conditions was first examined by Radok (1956) in solution of a moving punch problem in an infinite elastic medium. Broberg (1975, 1989) has examined the near-tip fields and directional stability of such crack propagation in elastic material both from the point of view of experimental observations and analytical approaches. Melin (1991) has recently used the finite element method using quarter-point singular elements for the evaluation of stability criteria of wedging in an elastic material.

5.1. Plane strain moving punch

The plane strain problem of steadily moving rigid punch wedging a semi-infinite crack in an infinite poroelastic medium is examined in this section. The indenter which moves with velocity V results in a steady self-similar extension of the crack. The crack extension

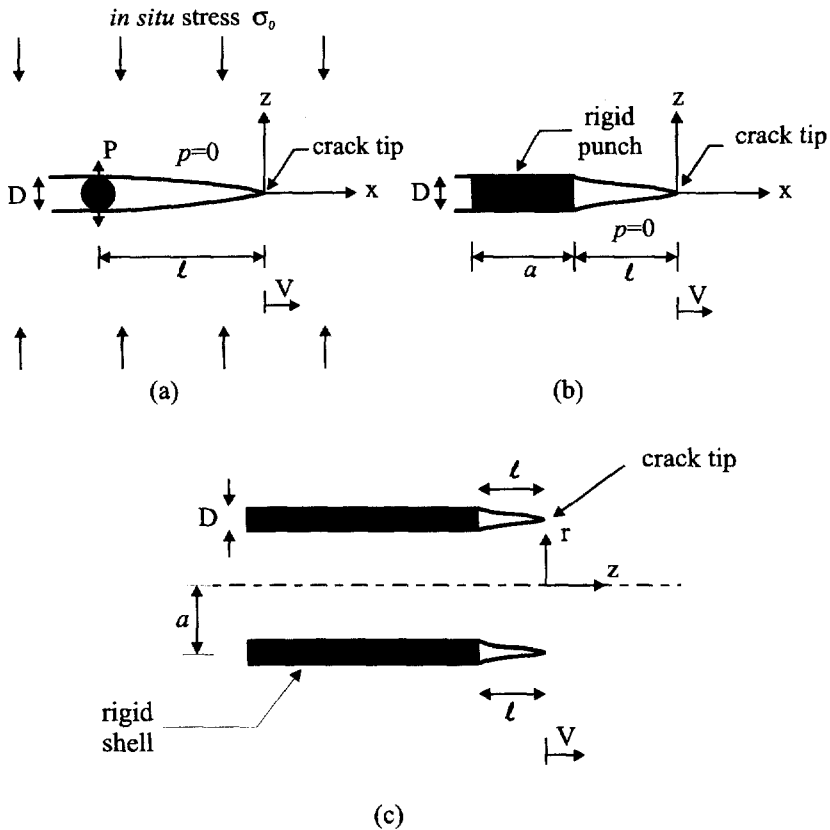

Fig. 6. Wedging of a poroelastic medium by rigid indentors.

criteria is governed by attainment of a critical stress intensity factor K_{IC} applicable to the porous fabric which depends on the propagation velocity. The shape of indenter is assumed to be either a cylinder of diameter D (i.e. the contact forces are idealized as a dipole of point forces) or a strip punch with a thickness of D and a length of a (Fig. 6). It is assumed that during steady state crack propagation, the crack tip takes its location at a distance l from the edge of indenter. The soil skeleton and the pore fluid of porous medium are assumed to be compressible with material parameters $\nu = 0.2$ and $\nu_u = 0.3$. Finite element discretization given in Fig. 3 is used for simulation purposes. The result of primary interest is the behaviour of crack-indentor interaction with variations in the *in situ* stresses σ_0 and the indenter geometry.

Figure 7(a) illustrates the variation of the crack opening stress intensity factor K_I with the geometry of crack and the *in situ* stresses σ_0 for a rigid smooth cylinder indenter moving at a velocity of $DV/C = 0.01$. This indicates that for higher *in situ* stresses and tougher materials, the resulting crack length is smaller. The effect of propagation velocity on the crack-indentor interaction behaviour is also illustrated in Fig. 7(b) in comparison with the static result for the problem with equivalent geometry (i.e. $V = 0$).

Figure 8 illustrates the crack extension criterion for a moving rigid strip which moves through a saturated porous medium at a velocity of $DV/C = 0.01$. It is assumed that the indenter always remains in full contact with porous medium. Similar crack-indentor interaction behaviour can be observed for various indenter geometries. It is also indicated that length of wedging indenter (a) in relation to crack length (l) has no significant effect on the steady crack propagation behaviour, for $a/l > 3$.

5.2. Axisymmetric penetration of a rigid shell

In this section we consider the problem of the steady penetration of a rigid cylindrical shell with smooth side walls and of finite thickness into a saturated poroelastic material of

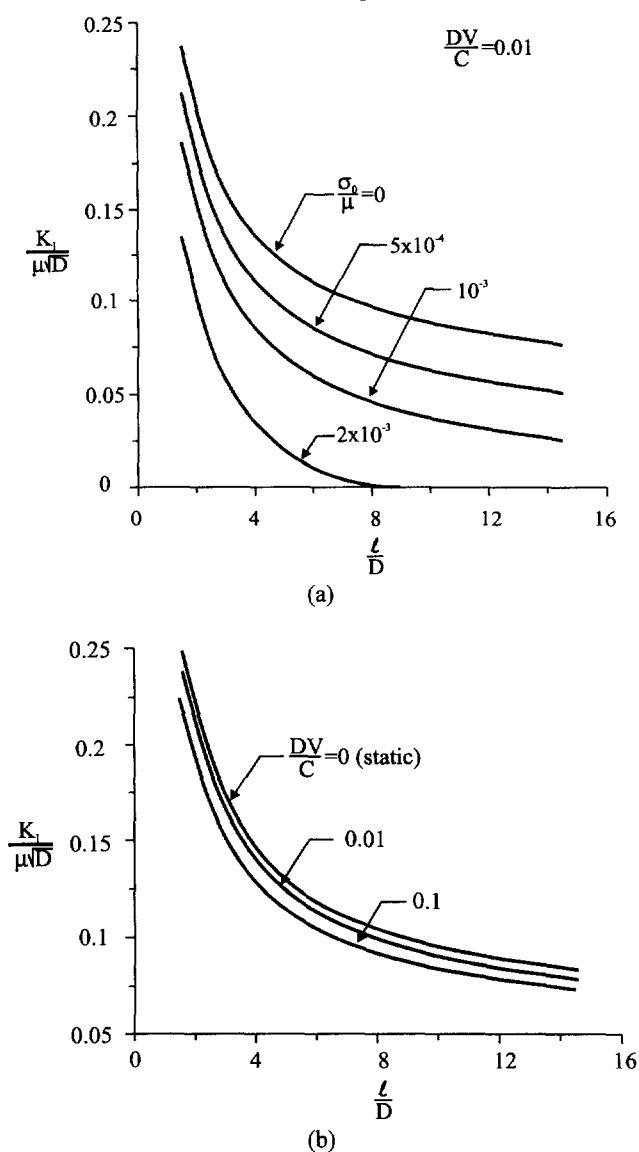
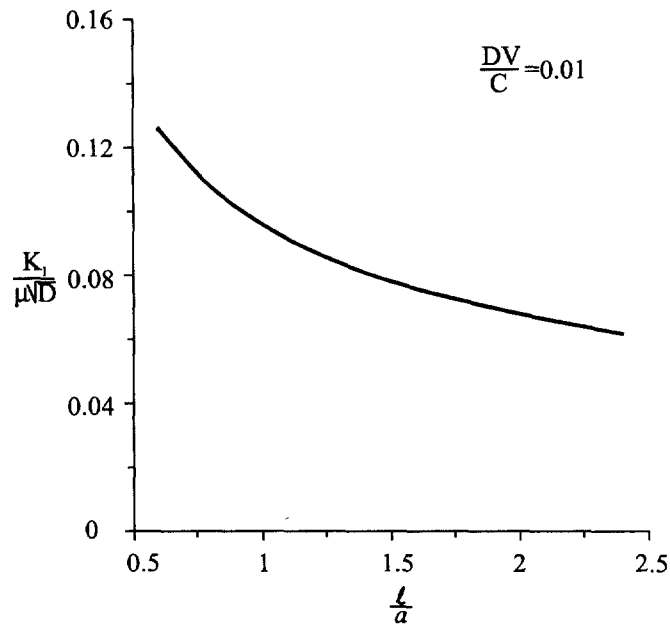
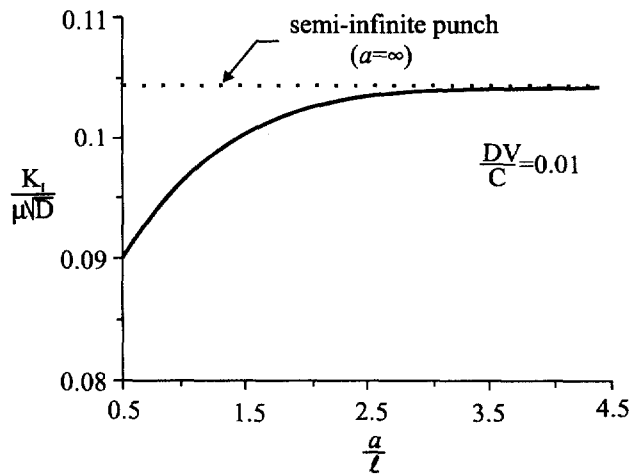

Fig. 7. Effect of crack geometry, *in situ* stresses, and propagation velocity on the stress intensity factor for a dipole joint point force wedging.

infinite extent. The problem represents one of the few situations where a three-dimensional axisymmetric problem gives rise to a self similar crack extension problem. As indicated previously, a steady expansion of a three-dimensional penny shaped crack does not result in a self similar problem. The problem could be of interest to the study of the penetration of the rigid casing of a shell into a saturated overconsolidated poroelastic medium which is susceptible to fracture rather than elasto-plastic yield. The situation could also be of interest to jacking of pipes in saturated overconsolidated soils. Admittedly, the constraint of smooth contact at the interface between the shell and the geomaterial is a restriction in the rigorous application of the problem to a practical situation. A further problem of interest would be the penetration of a solid pile with a conical end into a saturated poroelastic geomaterial. In this case however, the displacements involved during pile penetration would be significantly large so as to make the application of the theory of linear poroelasticity unwarranted. The problem of the penetrating cylindrical shell with the blunt end also complements the plane strain rigid punch problem, where, as the radius of the shell increases in comparison to the thickness of the shell, the two situations are expected to converge to the same result.



(a)



(b)

Fig. 8. Effect of crack and punch geometry on the stress intensity factor K_I for a wedging rigid strip.

The generalized problem examined here deals with the problem of a rigid cylindrical shell of thickness D and radius a (to the mid-section of the thickness D) which penetrates the saturated poroelastic geomaterial with a steady velocity V . Attention is restricted to the case where the shell has penetrated a sufficient distance into a poroelastic geomaterial region so as to warrant the modelling by appeal to a steady state condition encountered in the vicinity of the crack tip. The displacements are prescribed over the contact length of the penetrating shell and traction boundary conditions are prescribed over the crack opening region of length l . This length is controlled by the ratio K_I/K_{IC} of the saturated geomaterial. The pore pressures are assumed to be zero over the entire contact zone and the opened region l . The pore pressure boundary conditions that are applicable to a contact zone can vary between both fully permeable and impermeable boundary conditions. In view of the fact that the contact zone is assumed to be smooth, it is appropriate to take a zero pore pressure boundary condition at the contact zone. The set of moving coordinates are

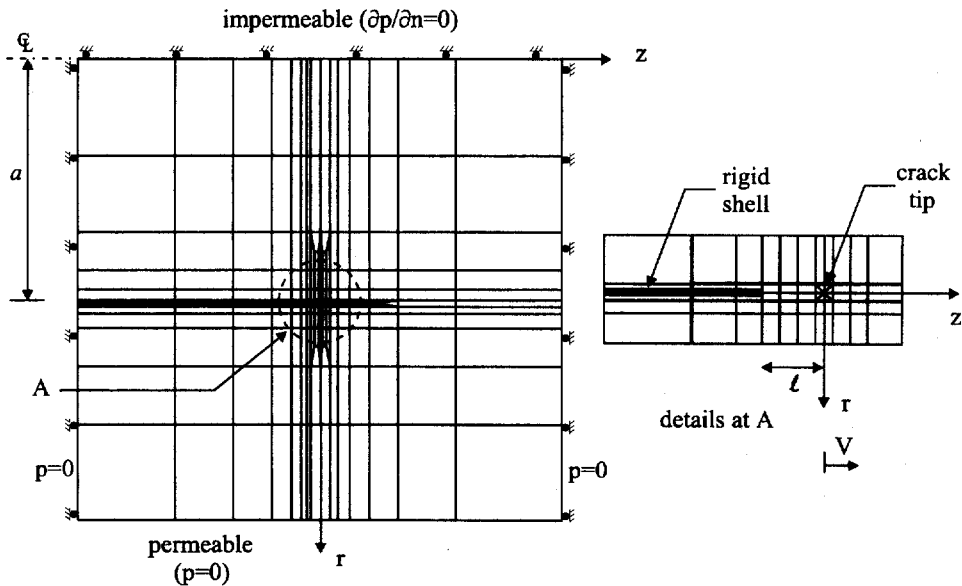

Fig. 9. Finite element discretization of the rigid shell penetration.

cylindrical polar coordinates (r, z) which are located along the axis of the penetrating shell and fixed to coincide with the plane containing the crack tip. The finite element discretization used in the modelling is shown in Fig. 9. The far field boundary conditions applicable to the problem are also shown in Fig. 9. There are several ways in which the results derived from the computations can be presented. Figure 10 illustrates the variation in the normalized crack opening mode stress intensity factor with the non-dimensional parameter

$$\frac{DV}{C} = \frac{9DV(1 - \nu_u)(\nu_u - \nu)}{2\kappa \tilde{B}^2 \mu(1 - \nu)(1 + \nu_u)^2} \quad (31)$$

which effectively represents the velocity to permeability ratio, which must satisfy the wave

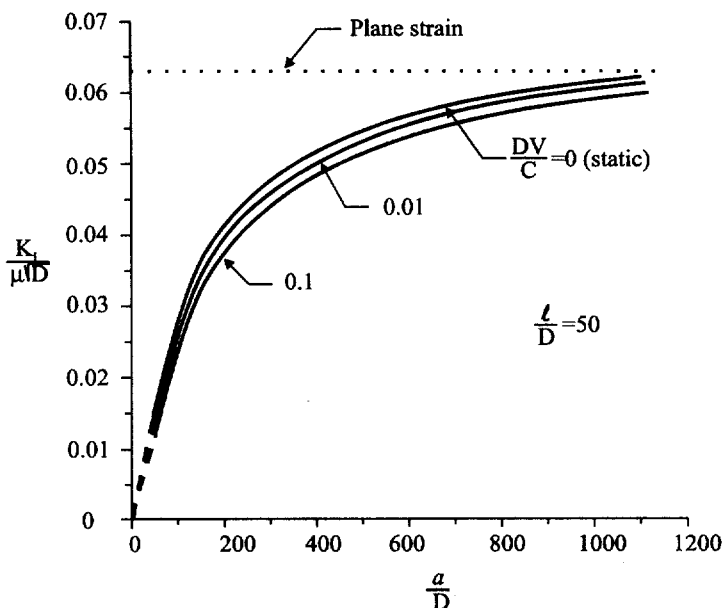

Fig. 10. Variation of the stress intensity factor K_I with radius a for a rigid smooth shell penetrating steadily through a poroelastic medium.

speed constraints discussed previously, the aspect ratio of the opened length to the shell thickness (l/D) and the aspect ratio of the shell geometries (a/D). The computations indicate that as a/D increases the result for the plane strain solution is recovered. The alternative presentation of results could include the evaluation of l/D which corresponds to maintaining $K_I/K_{IC} = 1$. This would require the specification of K_{IC} in the computations.

6. CONCLUDING REMARKS

An important class of problems arises in the study of steady moving boundary problems in the theory of poroelasticity. The steady state crack extension in poroelastic media is motivated by the potential application of the results to crack extension in brittle saturated media. An important step in the treatment of such problems is the introduction of a coordinate transformation which depends on the steady state velocity with which a discontinuity such as a crack moves within the poroelastic solid. This transformation has the effect of removing the time-dependency associated with the poroelasticity problem and reducing it to a conventional boundary value problem where only boundary conditions need to be prescribed on the displacement, traction and pore water pressure variables. This paper has presented the computational modelling of steady state crack extension problems via finite element modelling. The computational modelling accounts for the singular effective stress fields associated with the crack tip. The computational modelling is verified with analytical solutions available in the literature for steady crack extension in poroelastic media. It is shown that the computational modelling procedure successfully predicts the stress intensity factors at the crack tip and the pore pressure fields ahead of crack front. The versatility of the computational modelling procedure is demonstrated by application of the methodology to the study of the opening of a plane crack by a dipole of moving forces or a rigid punch with a uniform thickness. It is shown that the stress intensity factors at the crack tip due to the steady state movement of the crack tip can be evaluated quite conveniently by the numerical scheme. The versatility of the computational procedure is further established by considering for the first time a crack extension associated with a problem exhibiting axial symmetry. This involves the penetration of a thin cylindrical shell into a poroelastic solid. The computational procedure gives estimates for the stress intensity state factor K_I which can be compared with analogous results for the two-dimensional plane strain problem. This result has certain practical merit in that the relative geometric dimensions of the rigid shell (i.e. radius and thickness) which permits the consideration of a plane strain solution to an axisymmetric problem can be identified. The computational procedure represents an efficient technique which can be used to examine the factors of importance to steady state crack extension in brittle fluid saturated poroelastic geomaterials.

Acknowledgements—The work described in this paper was supported through a National Sciences and Engineering Research Council of Canada operating grant awarded to A. P. S. Selvadurai. The authors would like to thank the referees for their helpful comments and to Dr R. V. Craster for drawing attention to the cited references.

REFERENCES

- Atkinson, C. and Craster, R. V. (1991) Plane strain fracture in poroelastic media. *Proceedings of Royal Society A* **434**, 605–633.
- Barsoum, R. S. (1976) On the use of isoparametric finite elements in linear fracture mechanics. *International Journal for Numerical Methods in Engineering* **10**, 25–37.
- Biot, M. A. (1941) General theory of three-dimensional consolidation. *Journal of Applied Physics* **12**, 155–164.
- Biot, M. A. (1955) Theory of elasticity and consolidation for a porous anisotropic solid. *Journal of Applied Physics* **26**, 182–185.
- Booker, J. R. (1974) Time dependent strain following faulting of a porous medium. *Journal of Geophysical Research* **79**, 2037–2044.
- Boone, T. J., Ingraffea, A. R. and Roegiers, J. C. (1991) Simulation of hydraulic fracture in propagation in poroelastic rock with application to stress measurement techniques. *International Journal Rock Mechanics and Mining Sciences and Geomechanics Abstracts* **28**, 1–14.
- Broberg, K. B. (1960) The propagation of a brittle crack. *Archiv fur Fysik* **18**, 159–192.
- Broberg, K. B. (1975) *Reports of The Research Institute of Strength and Fracture of Materials*. Tohoku University **11**(1), 1–27.
- Broberg, K. B. (1989) The near-tip field at high crack velocities. *International Journal of Fracture* **39**, 1–13.

- Cheng, A. H. D. and Liggett, J. A. (1984) Boundary integral equation method for linear porous elasticity with applications to fracture propagation. *International Journal of Numerical Method in Engineering* **20**, 279–296.
- Craster, R. V. and Atkinson, C. (1996) Theoretical aspects of fracture in porous elastic media. *Mechanics of Poroelastic Media*, ed. A. P. S. Selvadurai. Kluwer Academic, Dordrecht, The Netherlands, pp. 30–54.
- Davis, R. O. and Selvadurai, A. P. S. (1996) *Elasticity and Geomechanics*. Cambridge University Press, Cambridge, U.K.
- Desroches, J., Detournay, E., Lenoach, B., Papanastasiou, P. C., Pearson, J. R. A., Thiercelin, M. and Cheng, A. H.-D. (1994) The crack tip region in hydraulic fracturing. *Proceedings of the Royal Society of London, Series A* **447**, 39–48.
- Detournay, E. and Cheng, A. H.-D. (1991) Plane strain analysis of a stationary hydraulic fracture in a poroelastic medium. *International Journal of Solids and Structures* **37**(13), 1645–1662.
- Freund, L. B. (1990) *Dynamic Fracture Mechanics*. Cambridge University Press, Cambridge, U.K.
- Ghaboussi, J. and Wilson, E. L. (1973) Flow of compressible fluid in porous elastic media. *International Journal for Numerical Methods in Engineering* **5**, 419–442.
- Henshell, R. D. and Shaw, K. G. (1975) Crack tip finite elements are unnecessary. *International Journal for Numerical Methods in Engineering* **9**, 495–507.
- Ingraffea, A. R. and Boone, T. J. (1988) Simulation of hydraulic fracture in poroelastic rock. *Proceedings of Conference on Numerical Methods in Geomechanics*, ed. G. Swoboda, Vol. 1, pp. 95–105. Balkema, Rotterdam.
- Lewis, R. W. and Schrefler, B. A. (1987) *The Finite Element Method in the Deformation and Consolidation of Porous Media*. John Wiley and Sons, New York.
- Melin, S. (1991) On the directional stability of wedging. *International Journal of Fracture* **50**, 293–300.
- Palmer, A. C. and Rice, J. R. (1973) The growth of slip surfaces in the progressive failure of overconsolidated clay. *Proceedings of the Royal Society of London, Series A* **332**, 527–548.
- Radok, J. R. M. (1956) On the solution of problems of dynamic plane elasticity. *Quarterly of Applied Mathematics* **14**, 289–298.
- Rice, J. R. and Cleary, M. P. (1976) Some basic stress diffusion solutions for fluid-saturated elastic porous media with compressible constituents. *Reviews of Geophysics and Space Physics* **14**, 227–241.
- Rice, J. R. and Simons, D. A. (1976) The stabilization of spreading shear faults by coupled deformation-diffusion effects in fluid-infiltrated porous material. *Journal of Geophysics Research* **81**, 5322–5334.
- Ruina, A. (1978) Influence of coupled deformation-diffusion effects on retardation of hydraulic fracture. *Proceedings of 19th U.S. Symposium in Rock Mechanics*, pp. 274–282. Nevada, U.S.A.
- Sandhu, R. S. and Wilson, E. L. (1969) Finite element analysis of flow in saturated porous media. *Journal of Engineering Mechanics Division, ASCE* **95**(EM3), 641–652.
- Selvadurai, A. P. S. (ed.) (1996) *Mechanics of Poroelastic Media*. Kluwer Academic, Dordrecht, The Netherlands.
- Selvadurai, A. P. S. and Nguyen, T. S. (1995) Computational modelling of isothermal consolidation of fractured porous media. *Computers and Geotechnics* **17**, 39–73.
- Simons, D. A. (1977) Boundary layer analysis of propagating mode II crack in porous elastic media. *Journal of Mechanics and Physics of Solids* **25**, 99–115.
- Skempton, A. W. (1954) The pore pressure coefficients *A* and *B*. *Geotechnique* **4**, 143–147.
- Yoffe, E. H. (1951) The moving Griffith crack. *Philosophical Magazine* **42**, 739–750.